



SHOP R06

(Lot S16), 110 Adderley Street, West Melbourne 3003

FOR SALE
\$1,813,000

Area: 197sqm



Video

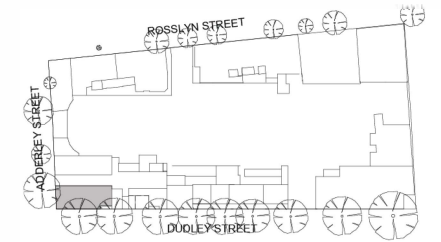
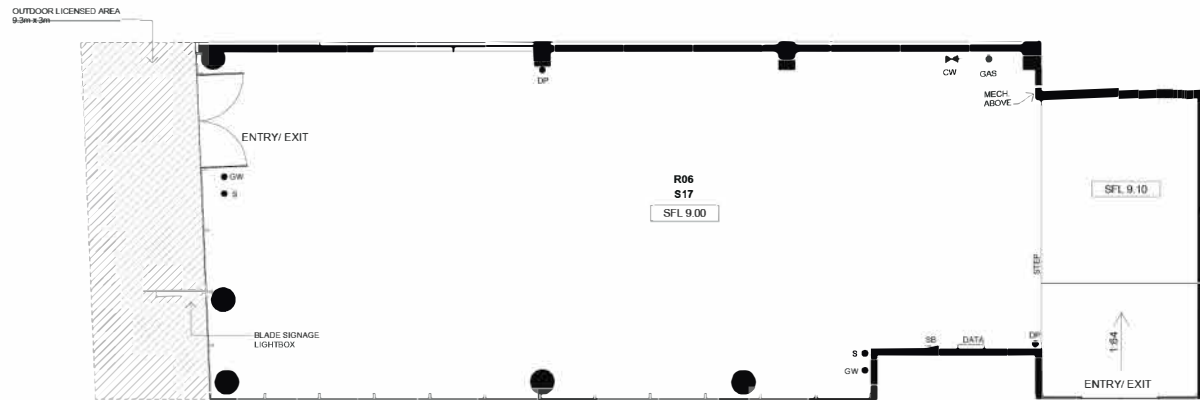

COMMERCIAL SPACE FOR SALE

CURRENT LEASE STATUS

Tenanted

Base rent: \$106,090 per annum

Term: 7 years **Option:** 5+5 years

| | |
|---------------------------------|--|
| Tenant: ShiRaaz by Rajputana | Tenant: ShiRaaz by Rajputana / West End Landco |
| Sale | Lease Expiry: 9 Mar 2028 |
| | 5+5 years |



Existing tenant: ShiRaaz by Rajputana

This is the second venue for this restaurant, first establishing themselves in the affluent Melbourne suburb of Brighton. The fine Indian cuisine restaurant serves traditional Indian meals at affordable prices, and also provides catering, delivery and takeaway.

ShiRaaz

COMMERCIAL SPACE FOR SALE